

PCM2000 Four to Six Zones

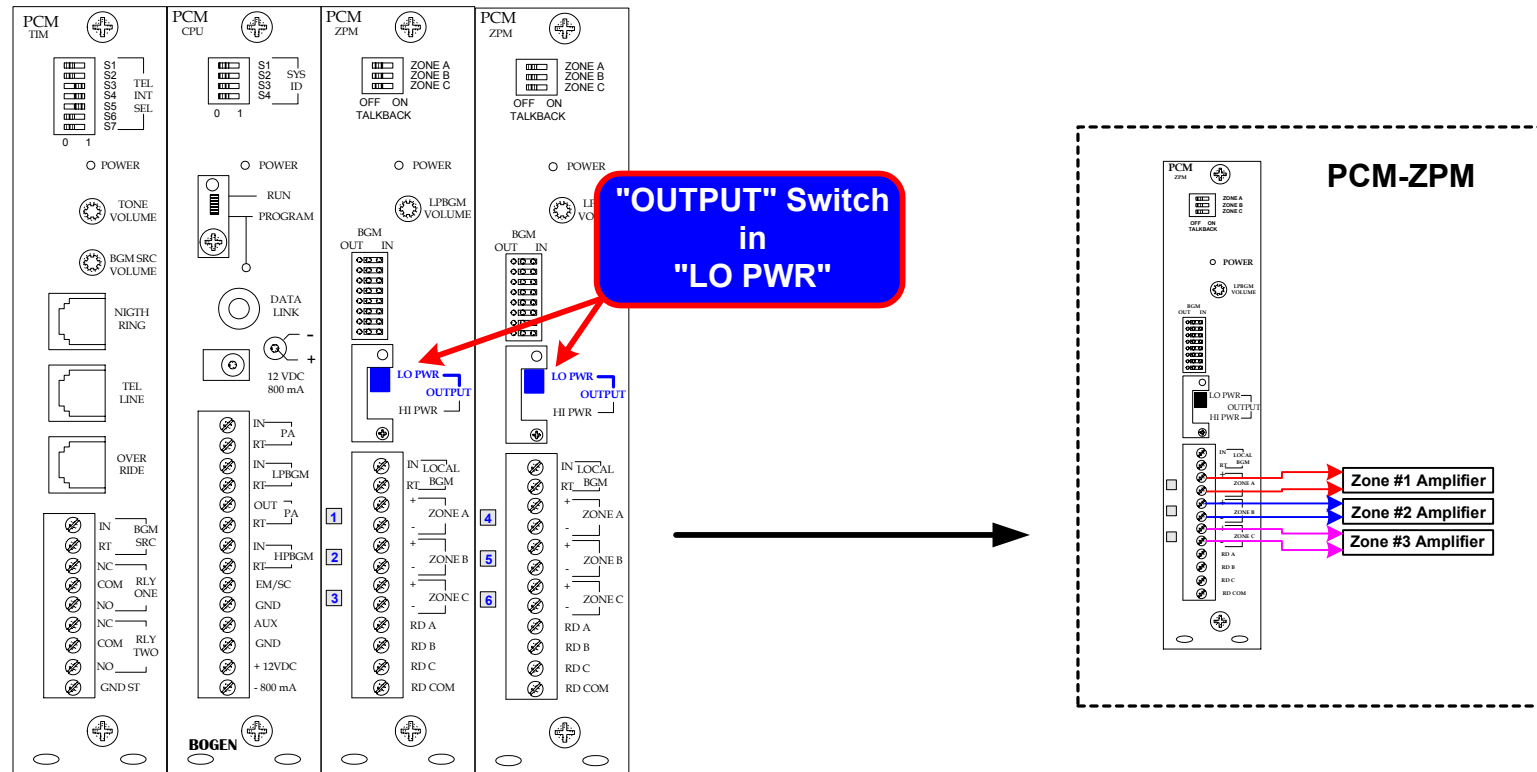

In the above configuration the output of the PCM-ZPM is a 600 ohm balanced line. This output is wired to the TEL input of the amplifier.

BLOCK DIAGRAM OF ANALOG DOOR PHONES WIRING TO TAMBS, TO WMT1A, TO GA2, TO DFT120, TO ZONE #1 AMPLIFIERS

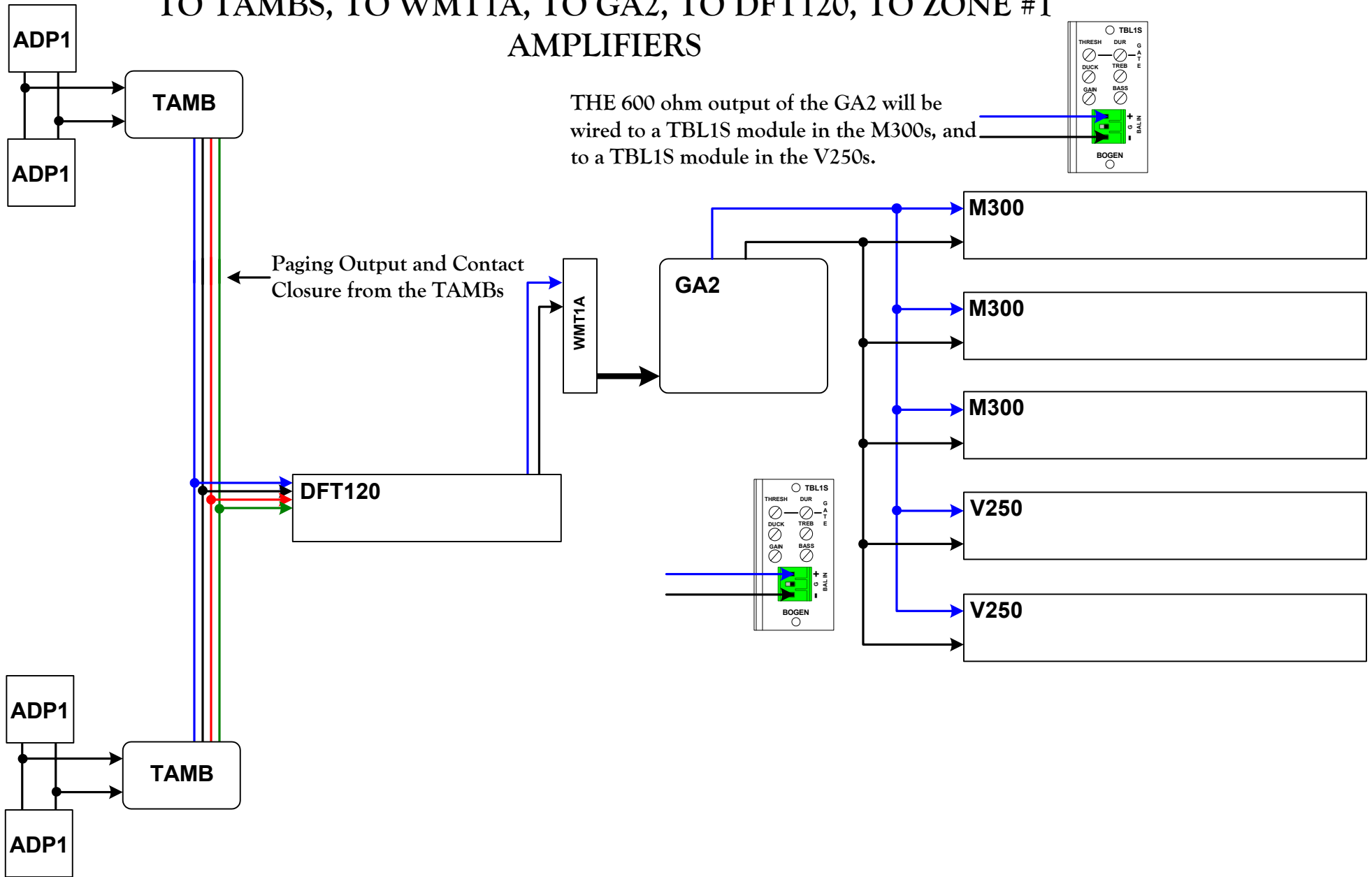

BLOCK DIAGRAM PCMZPM LO PWR ZONE #2

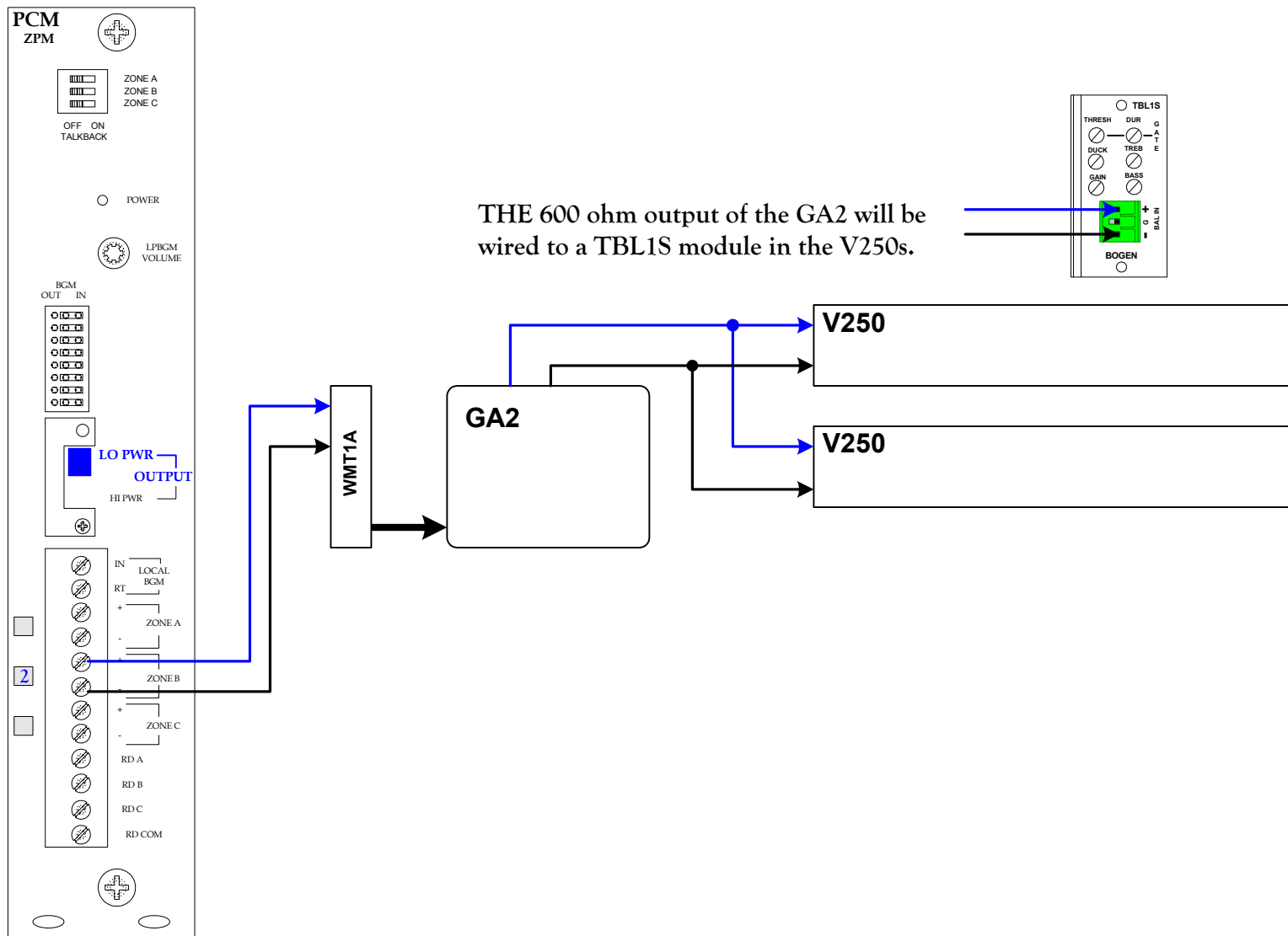

THE 600 ohm output of the GA2 will be wired to a TBL1S module in the V250s.

BLOCK DIAGRAM OF ANALOG DOOR PHONES WIRING TO TAMBS, TO WMT1A, TO GA2, TO DFT120, TO ZONE #2 AMPLIFIERS

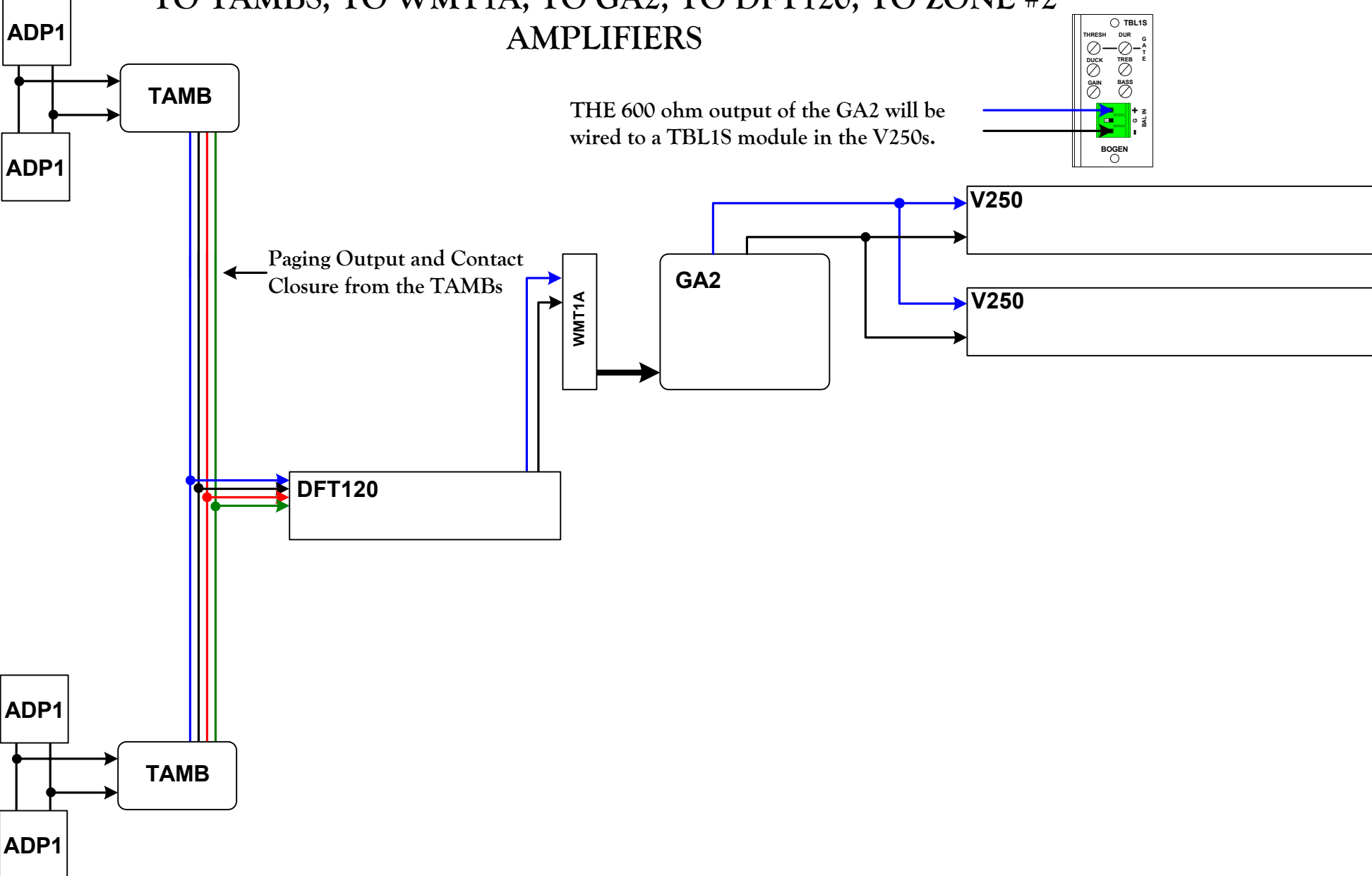

BLOCK DIAGRAM PCMZPM LO PWR ZONE #3

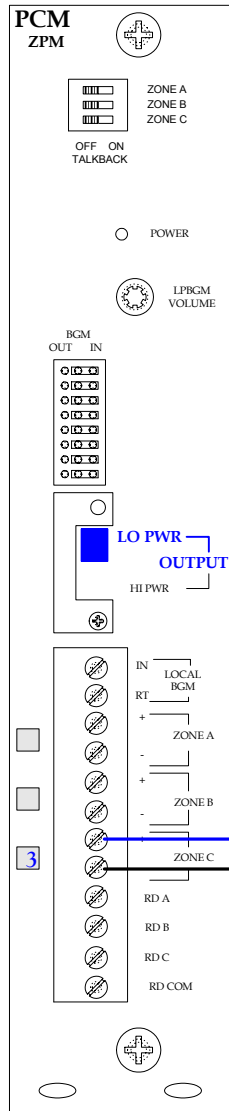

THE 600 ohm output of the GA2 will be wired to the aTBL1S module in the V100 and V250s.

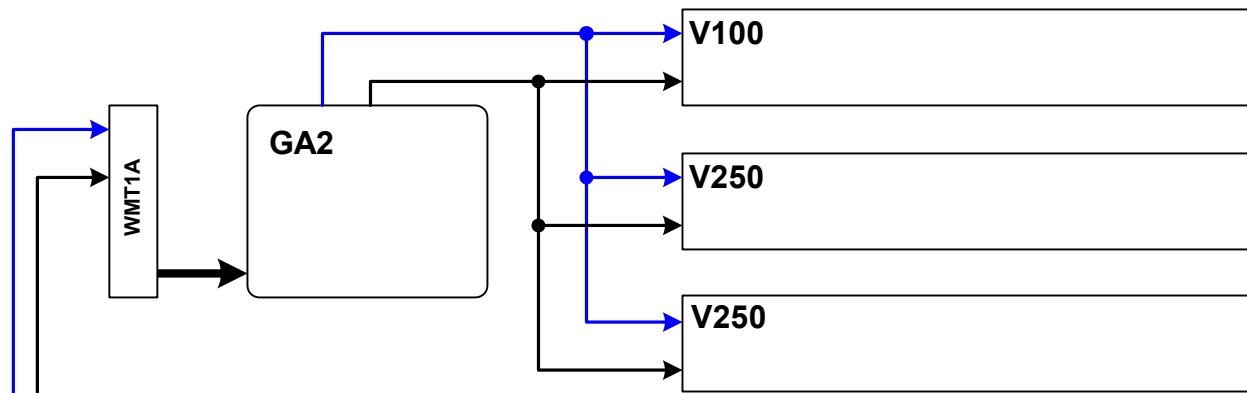
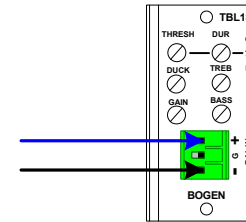

BLOCK DIAGRAM OF ANALOG DOOR PHONES WIRING TO TAMBS, TO WMT1A, TO GA2, TO DFT120, TO ZONE #3 AMPLIFIERS

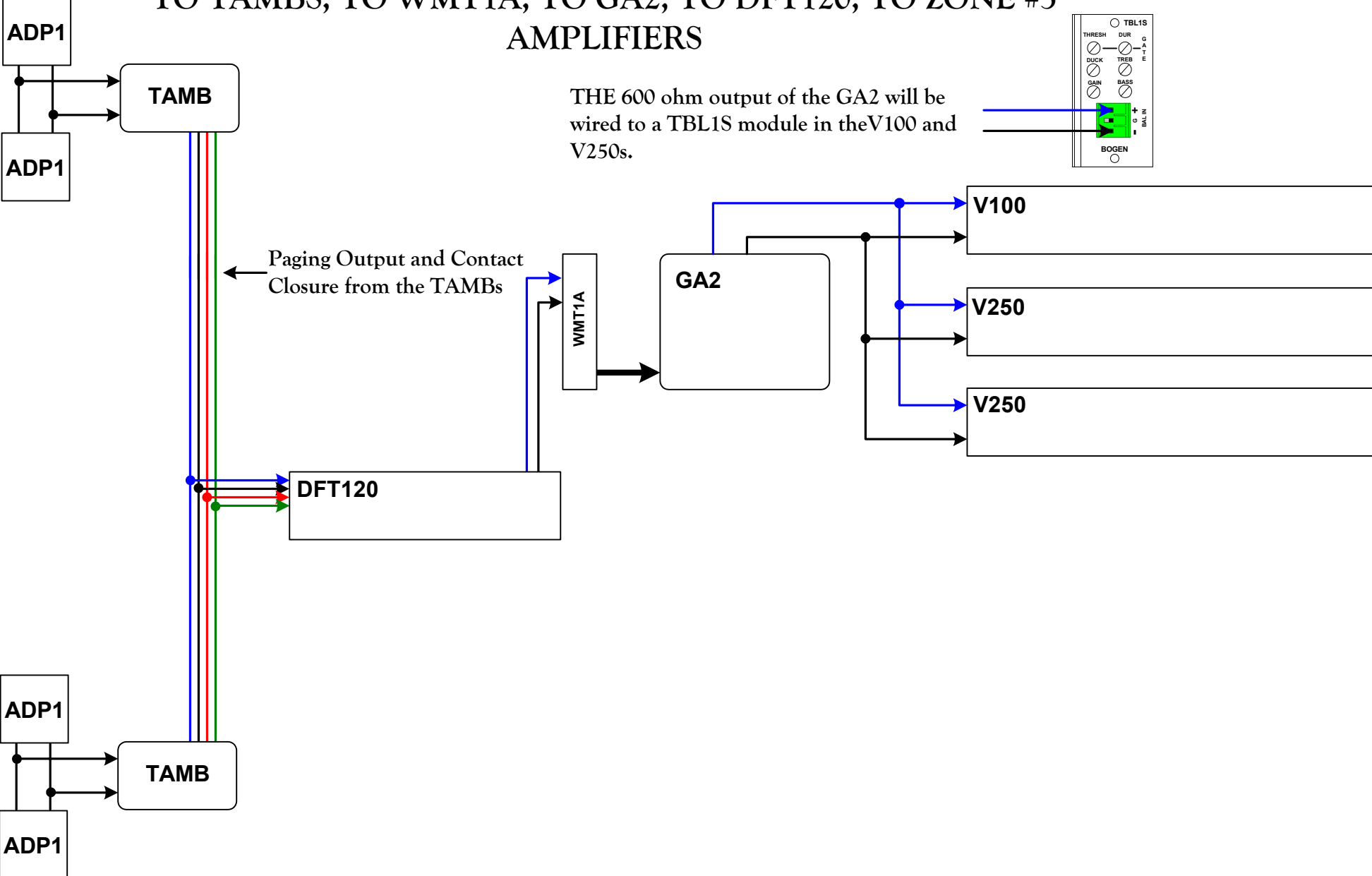

THE 600 ohm output of the GA2 will be wired to a TBL1S module in the V100 and V250s.

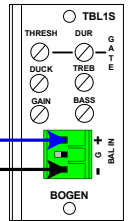

Paging Output and Contact Closure from the TAMBs

PCMZPM LO OUTPUT ZONE #4 PAGING

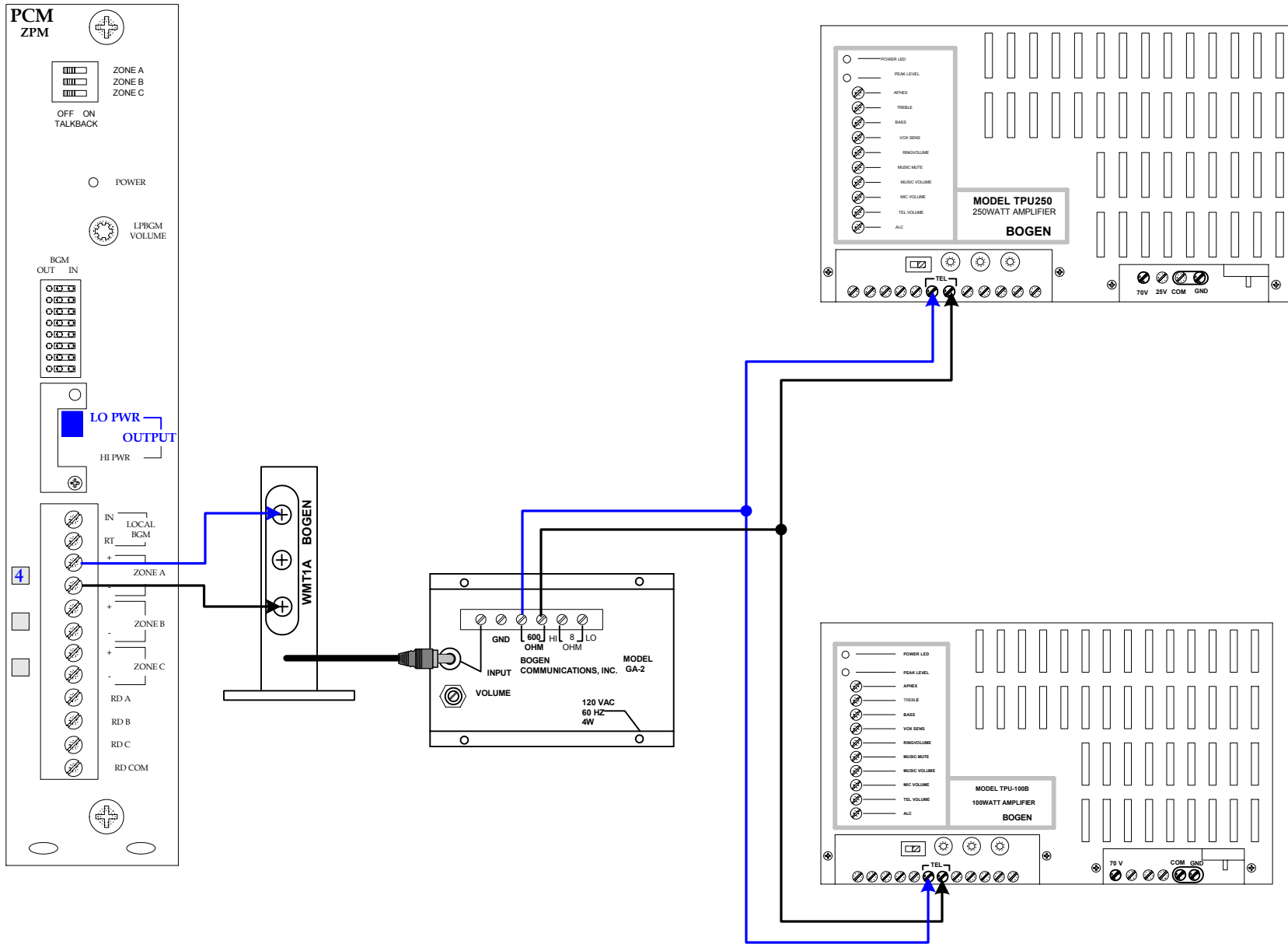

PCMZPM LO OUTPUT ZONE #5 PAGING

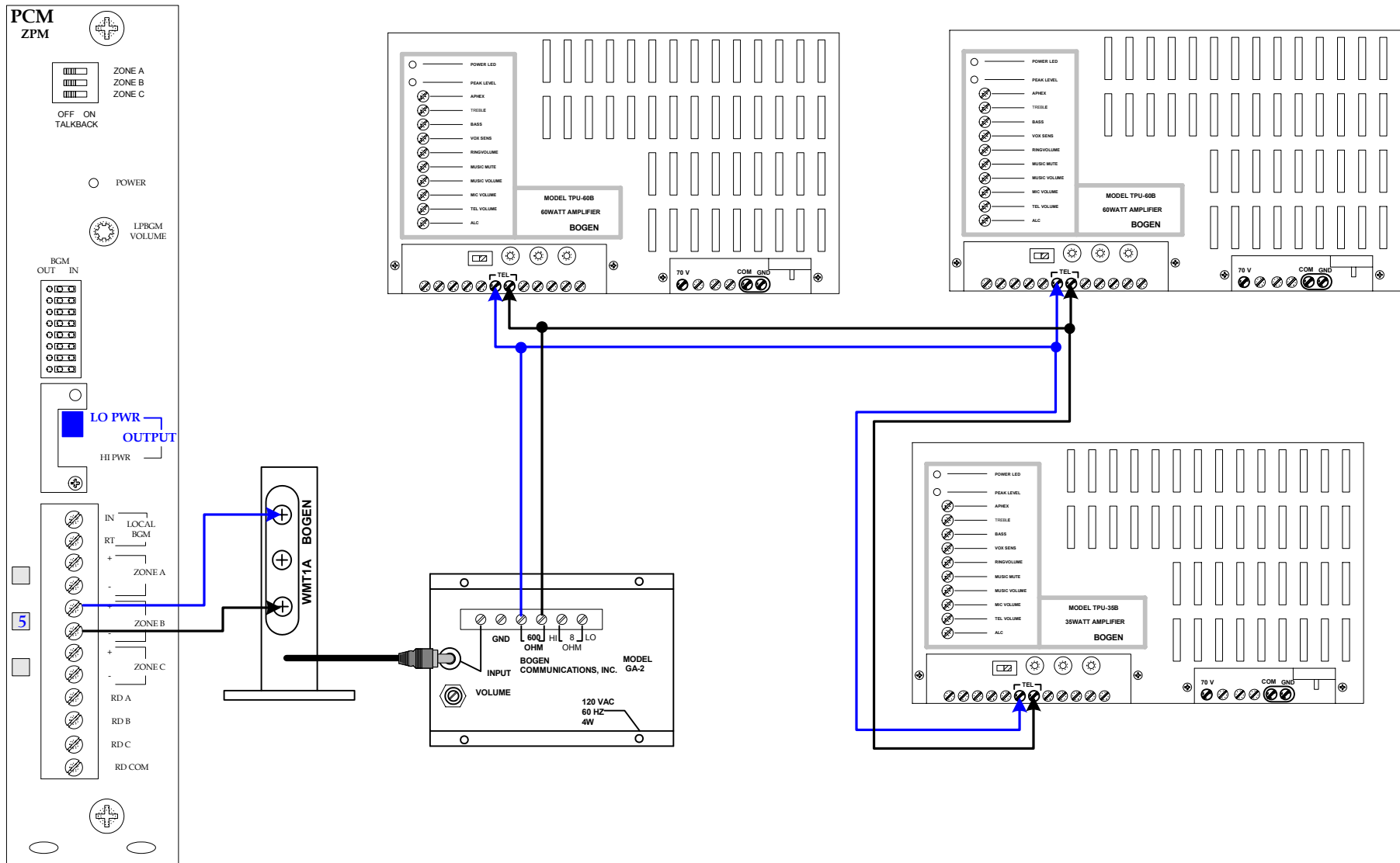

PCMZPM LO OUTPUT ZONE #6 PAGING

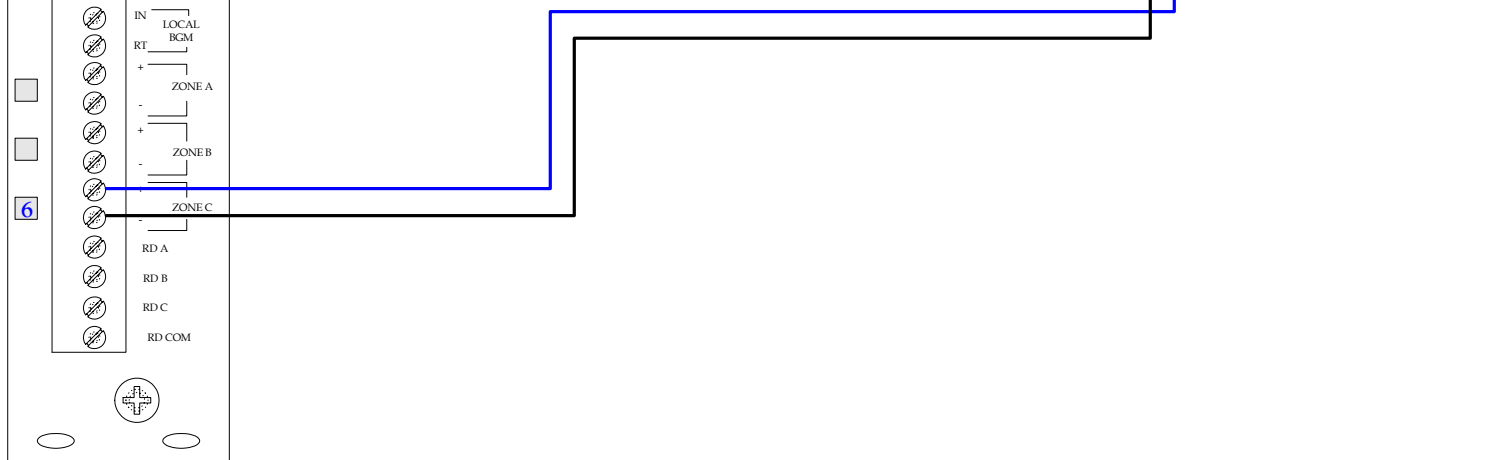
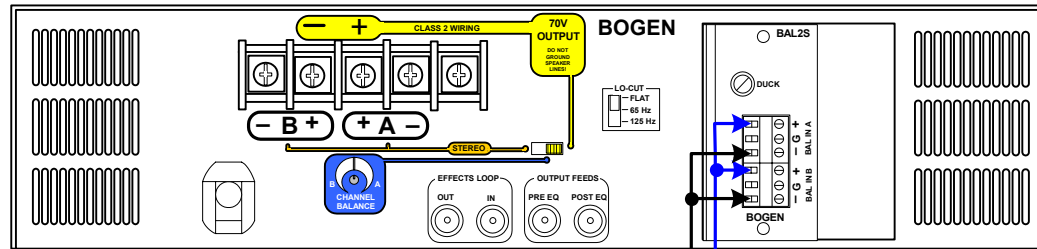
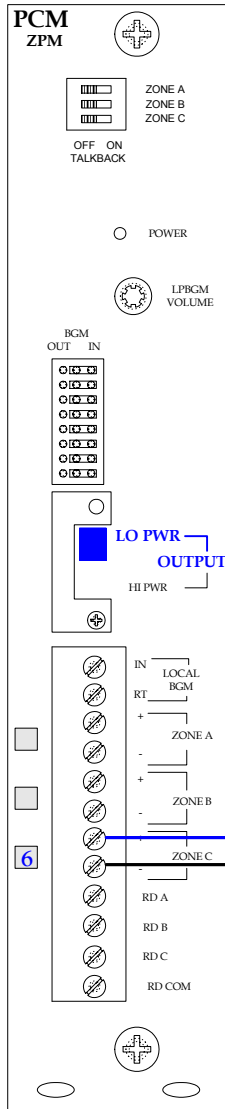

ADP1 Wires to be Cut and Removed

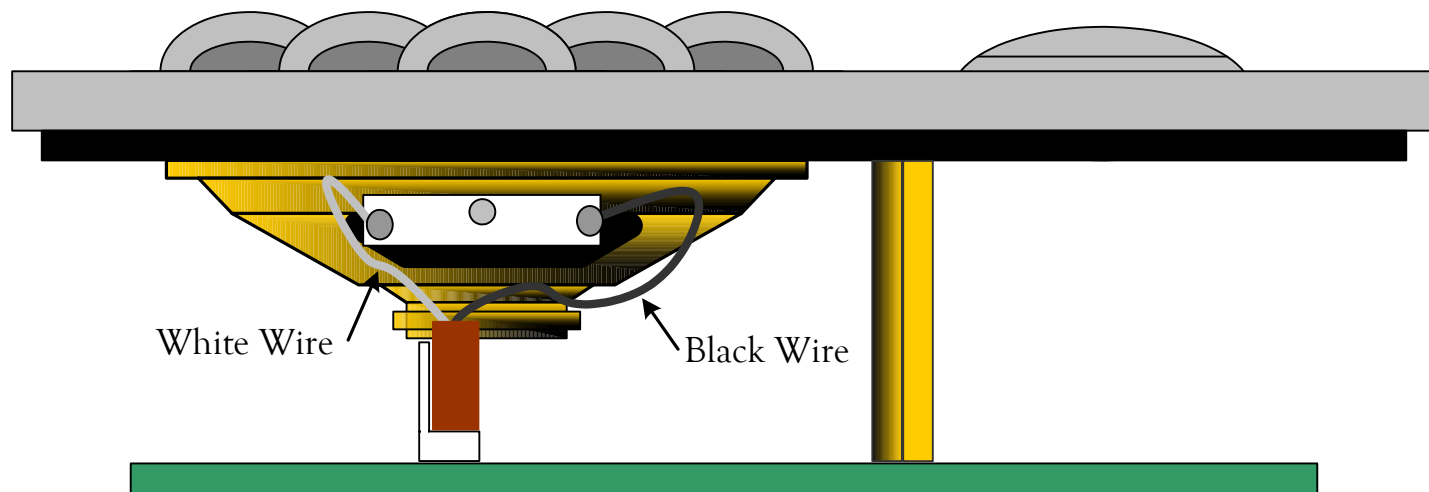

To disable the speaker Cut and Remove the White and Black wires to the speaker.

Wire Loss

Once you have an idea of how many speakers are to be wired together, estimate how long the wire run will be from the first to last speaker in each row. Include the lead-in wire length from the amplifier to the first speaker in each row in your overall run length. For each row, sum up the speaker power and cable lengths. Then refer to the chart to ensure that the wire gauge is sufficient to support the power and cable length desired. It may be necessary to increase the wire gauge or split the speaker loads to shorten the wire run lengths if they exceed the chart maximums.

Wire Loss Chart (10% of Power Lost in Wire)

Wire Gauge	Load Power Per Wire Run (Watts)						
	5	10	15	30	50	100	200
16	10,000	7,000	4,600	2,300	1,400	700	350
18	9,000	4,500	2,800	1400	830	415	205
20	5,500	2,700	1,800	900	540	270	135
22	3,400	1,700	1,100	550	330	115	60
24	2,100	1,000	700	350	210	105	50
Maximum Wire Run Cable Length (ft.)							